



SMAP L3 Radiometer Global and Northern Hemisphere Daily 36 km EASE-Grid Freeze/Thaw State, Version 2

USER GUIDE

How to Cite These Data

As a condition of using these data, you must include a citation:

Xu, X., R. S. Dunbar, C. Derksen, A. Colliander, Y. Kim, and J. S. Kimball. 2018. *SMAP L3 Radiometer Global and Northern Hemisphere Daily 36 km EASE-Grid Freeze/Thaw State, Version 2*. [Indicate subset used]. Boulder, Colorado USA. NASA National Snow and Ice Data Center Distributed Active Archive Center. <https://doi.org/10.5067/YN94K53QM061>. [Date Accessed].

FOR QUESTIONS ABOUT THESE DATA, CONTACT NSIDC@NSIDC.ORG

FOR CURRENT INFORMATION, VISIT <https://nsidc.org/data/SPL3FTP>



National Snow and Ice Data Center

TABLE OF CONTENTS

1	DATA DESCRIPTION	2
1.1	Parameters.....	2
1.2	Format.....	2
1.3	File Contents	2
1.4	Data Fields	3
1.4.1	Ancillary Data.....	4
1.4.2	Freeze/Thaw Retrieval Data	4
1.4.3	Radiometer Data.....	4
1.5	Metadata Fields.....	4
1.6	File Naming Convention.....	4
1.7	File Size.....	5
1.8	Volume	5
1.9	Spatial Coverage.....	5
1.10	Spatial Resolution	5
1.11	Projection and Grid Description.....	6
1.11.1	EASE-Grid 2.0.....	6
1.12	Temporal Information	6
1.12.1	Coverage.....	6
1.12.2	Temporal Resolution	7
2	DATA ACQUISITION AND PROCESSING.....	7
2.1	Sensor or Instrument Description.....	7
2.2	Data Source	7
2.3	Theory of Measurements	8
2.4	Derivation Techniques and Algorithms.....	8
2.4.1	Baseline Algorithm	8
2.4.2	Ancillary Data.....	10
2.5	Processing Steps	11
2.6	Error Sources	13
2.7	Quality Assessment.....	14
2.7.1	Quality Overview.....	15
3	CONTACTS AND ACKNOWLEDGMENTS	15
4	REFERENCES	16
5	DOCUMENT INFORMATION.....	18
5.1	Publication Date	18
5.2	Date Last Updated	18

1 DATA DESCRIPTION

1.1 Parameters

Freeze/thaw state and the direction of diurnal freeze/thaw transitions (frozen in the morning to thawed in the afternoon and vice versa) derived from brightness temperatures are output on a fixed Northern Hemisphere azimuthal EASE-Grid 2.0 at 36 km. Freeze/thaw state, the occurrence of freeze/thaw transitions, and the direction of transitions are expressed in boolean values (0 or 1). For freeze/thaw state, 0 indicates thawed conditions and 1 indicates frozen. For freeze/thaw transition state, 0 indicates the a.m. and p.m. FT states are the same (thawed/thawed or frozen/frozen). The transition direction flag is only meaningful if there is a transition (transition state = 1), and is set to 0 for a.m. frozen/p.m. thawed and 1 for a.m. thawed/p.m. frozen.

Also included are brightness temperatures (TBs) in kelvin for a 36 km EASE-Grid 2.0 cell.

Refer to the [Product Specification Document](#) for details on all parameters.

1.2 Format

Data are in HDF5 format. For software and more information, including an HDF5 tutorial, visit the HDF Group's [HDF5](#) Web site.

1.3 File Contents

As shown in Figure 1, each HDF5 file is organized into the following main groups, which contain additional groups and/or data sets:

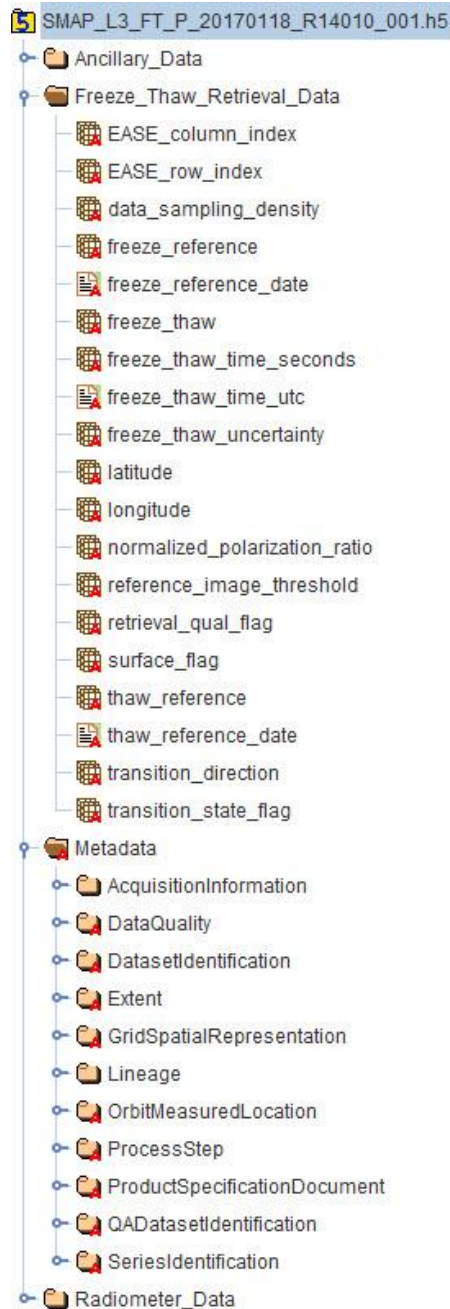

Figure 1. Subset of File Contents. For a complete list of file contents for the SMAP Level-3 radiometer freeze/thaw product, refer to the [Product Specification Document](#).

1.4 Data Fields

Each file contains the main data groups summarized in this section. For a complete list and description of all data fields within these groups, refer to the [Product Specification Document](#).

Data element arrays are three dimensional, with the exception of transition_direction and transition_state_flag arrays, which are two dimensional. All arrays have dimensions of 500 rows and 500 columns in each a.m. and p.m. layer. For the a.m./p.m. index of the array, the a.m. layer is assigned to the index value 0 and the p.m. layer is assigned to index value 1.

1.4.1 Ancillary Data

Includes all ancillary data, such as landcover classification and open water body fraction.

1.4.2 Freeze/Thaw Retrieval Data

Includes freeze/thaw data, latitude and longitude arrays, and associated quality assessment flags.

1.4.3 Radiometer Data

Includes all radiometer data and associated quality assessment flags.

1.5 Metadata Fields

Includes all metadata that describe the full content of each file. For a description of all metadata fields for this product, refer to the [Product Specification Document](#).

1.6 File Naming Convention

Files are named according to the following convention, which is described in Table 1:

SMAP_L3_FT_P_yyyymmdd_RLVvvv_NNN.[ext]

For example:

SMAP_L3_FT_P_20170117_R14010_001.h5

Table 1. File Naming Conventions

Variable	Description
SMAP	Indicates SMAP mission data
L3_FT_P	Indicates specific product (L3: Level-3; FT: Freeze/Thaw; P: Passive)
yyymm mdd	4-digit year, 2-digit month, 2-digit day; date in Universal Coordinated Time (UTC) of the first data element that appears in the product.

Variable	Description								
RLVvv v	<p>Composite Release ID (CRID), where:</p> <table border="1"> <tr> <td>R</td> <td>Release</td> </tr> <tr> <td>L</td> <td>Launch Indicator (1: Post-launch standard data)</td> </tr> <tr> <td>V</td> <td>1-Digit Major CRID Version Number</td> </tr> <tr> <td>vvv</td> <td>3-Digit Minor CRID Version Number</td> </tr> </table> <p>Refer to the SMAP Data Versions page for version information.</p>	R	Release	L	Launch Indicator (1: Post-launch standard data)	V	1-Digit Major CRID Version Number	vvv	3-Digit Minor CRID Version Number
R	Release								
L	Launch Indicator (1: Post-launch standard data)								
V	1-Digit Major CRID Version Number								
vvv	3-Digit Minor CRID Version Number								
NNN	Number of times the file was generated under the same version for a particular date/time interval (002: 2nd time)								
.[ext]	<p>File extensions include:</p> <table border="1"> <tr> <td>.h5</td> <td>HDF5 data file</td> </tr> <tr> <td>.qa</td> <td>Quality Assurance file</td> </tr> <tr> <td>.xml</td> <td>XML Metadata file</td> </tr> </table>	.h5	HDF5 data file	.qa	Quality Assurance file	.xml	XML Metadata file		
.h5	HDF5 data file								
.qa	Quality Assurance file								
.xml	XML Metadata file								

1.7 File Size

Each file is approximately 6.1 MB.

1.8 Volume

The daily data volume is approximately 6.1 MB.

1.9 Spatial Coverage

Coverage for this data set spans the Northern Hemisphere for all land regions north of 45°N latitude, and from 180°W to 180°E. The gap in coverage at the North Pole, called a pole hole, has a radius of approximately 400 km. The swath width is 1000 km, enabling nearly complete coverage of the Northern Hemisphere every three days.

1.10 Spatial Resolution

The native spatial resolution of the radiometer footprint is 36 km. Data are then gridded using the 36 km Northern Hemisphere azimuthal EASE-Grid 2.0 projection.

1.11 Projection and Grid Description

1.11.1 EASE-Grid 2.0

These data are provided on the Northern Hemisphere azimuthal EASE-Grid 2.0 (Brodzik et al. 2012). Each grid cell has a nominal area of approximately 36 x 36 km² regardless of longitude and latitude. Using this projection, all data arrays have dimensions of 500 rows and 500 columns.

EASE-Grid 2.0 has a flexible formulation. By adjusting a single scaling parameter, a family of multi-resolution grids that nest within one another can be generated. The nesting can be adjusted so that smaller grid cells can be tessellated to form larger grid cells. Figure 3 shows a schematic of the nesting.

This feature of perfect nesting provides SMAP data products with a convenient common projection for both high-resolution radar observations and low-resolution radiometer observations, as well as for their derived geophysical products. For more on EASE-Grid 2.0, refer to the [EASE-Grid 2.0 Format Description](#).

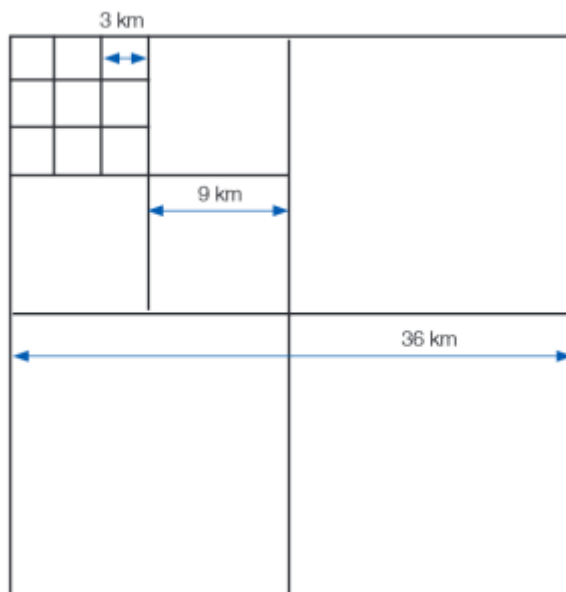

Figure 2. Perfect Nesting in EASE-Grid 2.0

1.12 Temporal Information

1.12.1 Coverage

Coverage spans from 31 March 2015 to 27 August 2021.

1.12.1.1 Temporal Coverage Gaps

Satellite and Processing Events

Due to instrument maneuvers, data downlink anomalies, data quality screening, and other factors, small gaps in the SMAP time series will occur. Details of these events are maintained on two master lists:

[SMAP On-Orbit Events List for Instrument Data Users](#)

[Master List of Bad and Missing Data](#)

1.12.1.2 Latencies

FAQ: [What are the latencies for SMAP radiometer data sets?](#)

1.12.2 Temporal Resolution

Each Level-3 file is a daily composite of half-orbit files/swaths.

To ensure complete coverage of the freeze/thaw domain in each daily file, a.m. and p.m. data for the current day are combined with a.m. and p.m. data from previous days. A maximum of three days of past data is used, and is necessary only near the southern margin of the freeze/thaw domain.

2 DATA ACQUISITION AND PROCESSING

2.1 Sensor or Instrument Description

For a detailed description of the SMAP instrument, visit the [SMAP Instrument](#) page at the JPL SMAP Web site.

2.2 Data Source

SMAP Level-3 radiometer freeze/thaw data (SPL3FTP) are derived from [SMAP L1C Radiometer Half-Orbit 36 km EASE-Grid Brightness Temperatures, Version 3 \(SPL1CTB\)](#).

2.3 Theory of Measurements

The SPL3FTP product is derived using a temporal change detection approach that has been previously developed and successfully applied using time-series satellite remote sensing radar backscatter and radiometric brightness temperature data from a variety of sensors and spectral wavelengths. The approach is to identify the landscape freeze/thaw (F/T) state via the temporal response of the normalized polarization ratio (NPR) of the brightness temperature, which is sensitive to changes in the dielectric constant of the landscape that occur as the water within the components transitions between frozen and non-frozen conditions.

This approach assumes that the large changes in dielectric constant occurring between frozen and non-frozen conditions dominates the corresponding NPR temporal dynamics across the seasons, rather than other potential sources of temporal variability such as changes in canopy structure and biomass, large precipitation events, or changes in soil moisture.

2.4 Derivation Techniques and Algorithms

This section has been adapted from Dunbar et al. (2016), the Algorithm Theoretical Basis Document (ATBD) for this data set.

The SMAP Level-3 radiometer freeze/thaw data set is derived from [SMAP L1C Radiometer Half-Orbit 36 km EASE-Grid Brightness Temperatures, Version 3 \(SPL1CTB\)](#). The derivation of freeze/thaw from SMAP brightness temperature measurements occurs during an intermediate Level-2 processing step of the input Level-1 brightness temperature data. During the Level-2 processing step, the freeze/thaw algorithm utilizes a seasonal threshold approach to convert SMAP brightness temperature measurements to freeze/thaw state. For an overview of the steps involved in processing this data product, refer to Figure 5 in the Processing Steps section.

2.4.1 Baseline Algorithm

The SPL3FTP freeze/thaw baseline algorithm examines the time series progression of the brightness temperature signature relative to signatures acquired during seasonal reference frozen and thawed states. The algorithm is applied to the normalized polarization ratio (NPR) of SMAP radiometer measurements

$$\text{NPR} = (\text{TBV} - \text{TBH}) / (\text{TBV} + \text{TBH}) \quad \text{(Equation 1)}$$

A seasonal scale factor $D(t)$ is defined for an observation acquired at time t as

$$D_t = (\text{NPR}(t) - \text{NPR}(\text{fr})) / (\text{NPR}(\text{th}) - \text{NPR}(\text{fr})) \quad \text{(Equation 2)}$$

where $NPR(t)$ is the normalized polarization ratio calculated at time t , for which a freeze/thaw classification is sought, and $NPR(th)$ and $NPR(fr)$ are normalized polarization ratios corresponding to the frozen and thawed reference states, respectively. The twenty highest (lowest) NPR values from SMAP radiometer measurements during July and August 2015 (thaw) and January and February 2016 (freeze) for the northern ($\geq 45^\circ N$) domain were retained and averaged to create the thaw (freeze) reference. Data were separated by ascending and descending orbit. The methodological approach to NPR freeze and thaw references will be refined in future product releases. In addition, the reference values will be updated following each transition season. Reprocessing of the SMAP data record incorporating annual variations in the SMAP freeze/thaw reference states should improve product accuracy over the use of static reference conditions. The initial SMAP freeze and thaw NPR references are shown in Figure 4 below (and Section 4.2.2 of the ATBD).

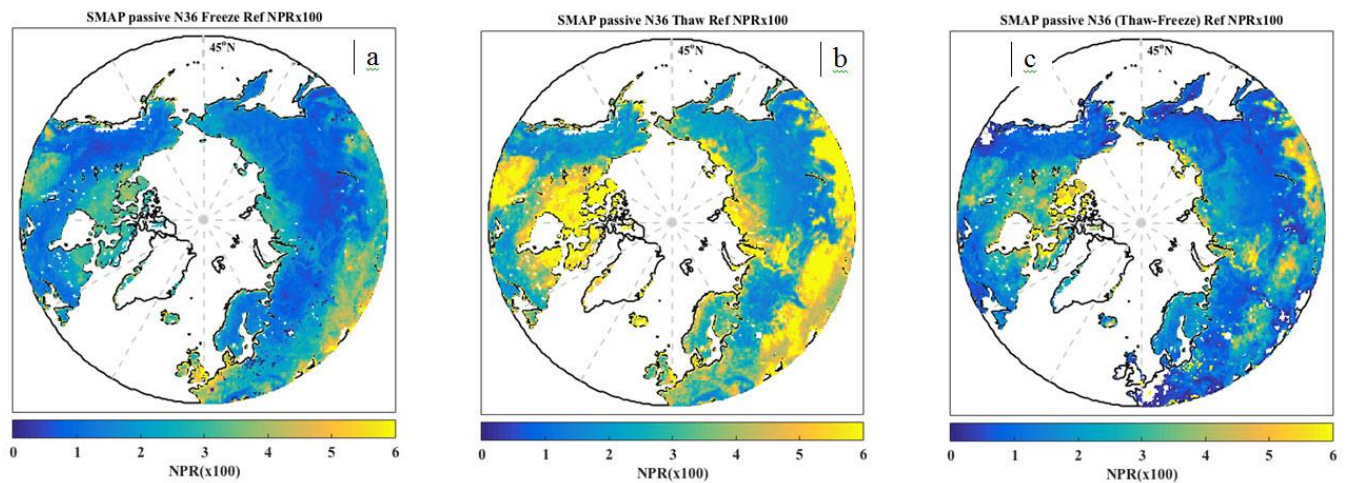

Figure 3. Initial SMAP Freeze and Thaw NPR References. SMAP radiometer (a) freeze and (b) thaw references; (c) reference difference between panels (a) and (b). Units are NPR scaled by 100.

A threshold level T is then defined such that

$$D(t) > T$$

$$D(t) \leq T \quad \text{(Equation 3)}$$

defines the thawed and frozen landscape states, respectively. This series of equations (1-3) are run on a grid cell-by-cell basis for unmasked portions of the FT domain. The output from Equation (3) is a dimensionless binary state variable designating either frozen or thawed conditions for each unmasked grid cell. The threshold values can be optimized on a grid cell by grid cell basis, but are fixed at 0.5 for this release. Optimization approaches will be evaluated in advance of future product releases.

Following the pixel-wise determination of freeze/thaw state, two additional processing steps are applied to mitigate summer season false freeze and winter season false thaw retrievals. First, if the brightness temperature magnitude at either V or H pol is greater than 273 K, the pixel is set to thaw regardless of the retrieval. Second a temporally fixed 'never frozen' mask calculated from daily AMSR-E freeze/thaw maps (using the approach described in Kim et al., 2012) is applied to remove obviously false summer freeze flags. False freeze retrievals occur in some regions of the F/T domain because of small differences between the reference freeze and thaw values (see Figure 4c). Implementation of daily AMSR-E-derived 'never frozen' and 'never thawed' masks in future product releases will address this issue.

2.4.2 Ancillary Data

Ancillary data sets are used to:

1. Support initialization of the thresholds employed in the algorithm
2. Set flags that indicate potential problem regions
3. Define masks where no retrievals should be performed

Ancillary data used in SPL3FTP processing includes data sets of inland open water, permanent ice and snow, and urban areas in order to derive masks so that no retrievals occur over these regions. Ancillary data sets of mountainous areas, fractional open water cover, and precipitation are used to derive flags so that a confidence interval can be associated with the retrieval. All ancillary data sets are resampled to a spatial scale and geographic projection that matches the SPL3FTP product in accordance with the guidelines of the SMAP mission.

Ancillary data sets used for SPL3FTP data processing were in place prior to launch, with no need for periodic updates during post-launch operations. A continuous surface map of fractional area of open water was used to represent fractional water coverage within a grid consistent with the resolution and projection of the SPL3FTP product. For the SPL3FTP development, the lake fraction threshold within a grid cell was set to 50%. Determination of a physically-based lake fraction will be finalized for a forthcoming SPL3FTP release. Table 3 lists the ancillary data employed in support of SPL3FTP production. Similar ancillary data were used for production of the SMAP radar freeze/thaw (SPL3FTA) product.

Table 2. Input Ancillary Data for SPL3FTP

Data Type	Data Source(s)	Frequency	Resolution	Extent	Use
Vegetation Type	Moderate Resolution Imaging Spectroradiometer International Geosphere Biosphere Programme (MODIS-IGBP)	Once	250 m	Global	Sensitivity Analysis
Precipitation	European Center for Medium Range Weather Forecasting (ECMWF) Forecasts	Time of Acquisition	0.25 degrees	Global	Sensitivity Analysis
Static Water Bodies	MODIS Land-Water Mask (MODIS44W)	Once	250 m	Global	Mask/Flag
Mountainous Areas	NASA Global Digital Elevation Model (DEM)	Once	30 m	Global	Mask/Flag
Permanent Ice and Snow	MODIS-IGBP Permanent Ice and Snow Class	Once	500 m	Global	Mask/Flag
Seasonal Snow	National Oceanic and Atmospheric Administration/National Ice Center Interactive Multisensor Snow and Ice Mapping System (NOAA IMS)	Daily	1 km	Northern Hemisphere	Flag
Never-Thawed/Never-Frozen Masks	Advanced Microwave Scanning Radiometer - Earth Observing System (AMSR-E)	Annual	25 km	Northern Hemisphere	False Flag Mitigation

For more information, refer to the [ATBD](#) for this product.

2.5 Processing Steps

This product is generated by the SMAP Science Data Processing System (SDS) at the Jet Propulsion Laboratory (JPL) in Pasadena, California USA. Figure 5 shows the processing sequence for generation of the SMAP L3 freeze/thaw (F/T) radiometer product (SPL3FTP).

The derivation of freeze/thaw from SMAP brightness temperature measurements occurs during an intermediate Level-2 processing step of the input Level-1 brightness temperature data. During the Level-2 processing step, the freeze/thaw algorithm utilizes a seasonal threshold approach to convert SMAP brightness temperature measurements to freeze/thaw state.

To generate this product, the processing software:

1. Ingests one day's worth of Level-1 files and creates individual Northern Hemisphere composites as two-dimensional or three-dimensional arrays for each output parameter defined in the Level-1 data
2. Intermediate Level-2 processing step: Converts SMAP brightness temperature measurements to freeze/thaw state. Classifies frozen and thawed landscape states on a grid cell-by-cell basis for unmasked portions of the FT domain by:
 - A. Utilizing the NPR of SMAP radiometer measurements during seasonal reference frozen and thawed states
 - B. Applying a fixed threshold of 0.5 to determine either frozen or thawed conditions relative to the reference states
 - C. Employing ancillary data sets to set flags for potential problem regions, and define masks where no retrievals should be performed
 - D. Mitigating summer season false freeze and winter season false thaw retrievals by:
 - a. Designating pixels as 'thaw' when TB magnitude at V or H pol is greater than 273 K
 - b. Applying a fixed AMSR-E derived 'never frozen' mask
3. The processing software then combines a.m. and p.m. data for the current day with a.m. and p.m. data from previous days to ensure complete coverage of the freeze/thaw domain in each daily file. Note that a maximum of three days of past data is used, and is necessary only near the southern margin of the freeze/thaw domain. Wherever data overlap occurs, as is typical at high latitudes, data which were acquired closest to 6:00 a.m. and 6:00 p.m. local solar times are chosen.

For details regarding each of these processing steps, refer to the Derivation Techniques and Algorithms section of this document.

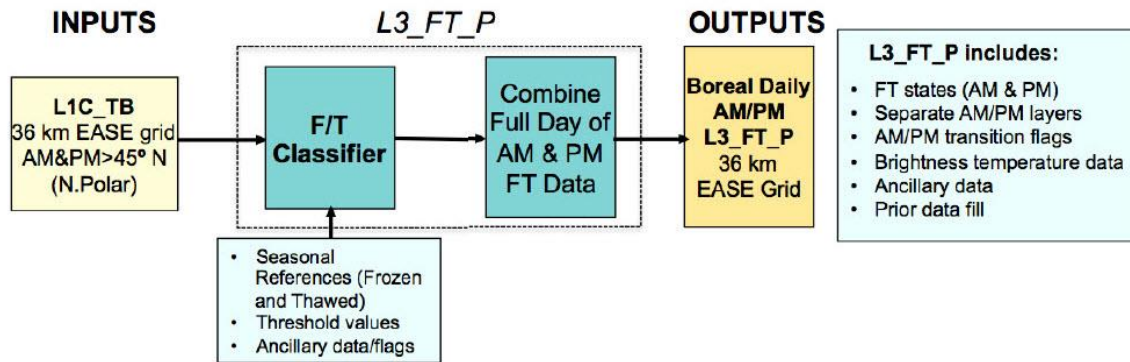

Figure 4. Processing Sequence for the L3 Freeze/Thaw Radiometer Product (SPL3FTP)

As a result, the output Level-3 radiometer freeze/thaw product distinguishes four levels of freeze/thaw conditions determined from the ascending 6:00 a.m. and descending 6:00 p.m. [SPL1CTB](#) data, including:

- Frozen (from both a.m. and p.m. overpass times)
- Non-frozen (a.m. and p.m.)
- Transitional (a.m. frozen; p.m. non-frozen)
- Inverse-transitional (a.m. non-frozen; p.m. frozen)

For more information on the algorithm processing flow, refer to the [ATBD](#) for this product, Section 2.2: L3_FT_P Production.

2.6 Error Sources

Anthropogenic Radio Frequency Interference (RFI), principally from ground-based surveillance radars, can contaminate both radar and radiometer measurements at L-band. The SMAP radar and radiometer electronics and algorithms include design features to mitigate the effects of RFI. The SMAP radiometer utilizes selective filters and an adjustable carrier frequency to tune to predetermined RFI-free portions of the spectrum while on orbit.

The landscape freeze/thaw state retrieval represented by the SPL3FTP algorithm and products characterizes the predominant frozen or non-frozen state of the land surface within the sensor Field of View (FOV) and does not distinguish freeze/thaw characteristics among different landscape elements, including surface snow, soil, open water or vegetation. The lower frequency L-band retrievals from SMAP are expected to have greater sensitivity to surface soil freeze/thaw conditions under low to moderate vegetation cover. Microwave freeze/thaw sensitivity is strongly constrained

by intervening vegetation biomass, soil moisture levels, and snow wetness. Ambiguity in relating changes in the radiometer signal to these specific landscape components is a challenge to validation of the freeze/thaw product (Colliander et al., 2012). In northern boreal and tundra landscapes, L-band penetration depth is greater under frozen conditions when land surface liquid water levels are low, and markedly reduced under thawed conditions due to characteristically moist surface organic layer and soil active layer conditions, even under relatively low tundra vegetation biomass levels (Du et al. 2014).

Note that spatial classification error is expected to be larger in regions with small differences between frozen and thawed NPR references. This includes areas where: freeze/thaw is ephemeral and densely vegetated areas due to vegetation scattering effects on microwave emissivity, which reduces TB V and H-polarization differences and NPR dynamic range. In regions of complex terrain, freeze/thaw heterogeneity is greater which also adversely impacts retrieval performance. In arid regions, the small amount water present in the thawed state makes the soil permittivity close to the frozen state, which can cause false freeze retrieval errors.

Finally, a major assumption of the seasonal threshold based temporal change freeze/thaw classification is that the major temporal shifts in brightness temperature are caused by land surface dielectric changes from temporal freeze/thaw transitions. This assumption generally holds for higher latitudes and elevations where seasonal frozen temperatures are a significant part of the annual cycle and a large constraint to land surface water mobility and ecosystem processes (e.g., Kim et al. 2012). However, freeze/thaw classification accuracy is expected to be reduced where other environmental factors may cause large temporal shifts in brightness temperature, including large rainfall events and surface inundation, and changes in vegetation biomass (e.g. phenology, disturbance and land cover change). While there is a strong NPR response to freeze/thaw transitions, NPR is not stable during summer due to the influence of vegetation, soil moisture, etc. Depolarization of summer season measurements leads to false freeze retrievals that must be mitigated. Winter season false thaw in areas of complex terrain are due to uncertainty in the references due to sub-grid heterogeneity.

For an assessment of algorithm performance and sources of uncertainty using in situ observations, and other satellite data sets, refer to the [Validated Assessment Report](#) for this product.

2.7 Quality Assessment

For in-depth details regarding the quality of these Version 1 Validated data, refer to the following report:

[Validated Assessment Report](#)

2.7.1 Quality Overview

The SPL3FTP product has sufficient fidelity and accuracy to identify the primary seasonal freeze and thaw transitions, and distinguish diurnal freeze/thaw state changes common during seasonal transitions.

SMAP products provide multiple means to assess quality. Each product contains bit flags, uncertainty measures, and file-level metadata that provide quality information. For information regarding the specific bit flags, uncertainty measures, and file-level metadata contained in this product, refer to the [Product Specification Document](#).

Each HDF5 file contains metadata with Quality Assessment (QA) metadata flags that are set by the Science Data Processing System (SDS) at the JPL prior to delivery to the National Snow and Ice Data Center Distributed Active Archive Center (NSIDC DAAC). A separate metadata file with an .xml file extension is also delivered to NSIDC DAAC with the HDF5 file; it contains the same information as the HDF5 file-level metadata.

A separate QA file with a .qa file extension is also associated with each data file. QA files are ASCII text files that contain statistical information in order to help users better assess the quality of the associated data file.

If a product does not fail QA, it is ready to be used for higher-level processing, browse generation, active science QA, archive, and distribution. If a product fails QA, it is never delivered to NSIDC DAAC.

3 CONTACTS AND ACKNOWLEDGMENTS

Investigators

Xiaolan Xu, Scott Dunbar, Andreas Colliander

Jet Propulsion Laboratory
California Institute of Technology
Pasadena, CA 91109 USA

Chris Derksen

Climate Research Division
Environment and Climate Change Canada
Toronto, ON M3H 5T4 Canada

John Kimball, Youngwook Kim

Numerical Terradynamic Simulation Group (NTSG)

College of Forestry & Conservation

The University of Montana

Missoula, MT 59812-1049 USA

4 REFERENCES

Brodzik, M. J., B. Billingsley, T. Haran, B. Raup, and M. H. Savoie. 2012. EASE-Grid 2.0: Incremental but significant improvements for Earth-gridded data sets. *ISPRS Int. J. Geo-Inf.* 1(1):32-45. <http://dx.doi.org/10.3390/ijgi1010032>.

Brodzik, M. J., B. Billingsley, T. Haran, B. Raup, and M. H. Savoie. 2014. Correction: Brodzik, M. J. et al. EASE-Grid 2.0: Incremental but significant improvements for Earth-gridded data sets. *ISPRS Int. J. Geo-Inf* 2012. 1(1):32-45 *ISPRS Int. J. Geo-Inf.* 3(3):1154-1156. <http://dx.doi.org/10.3390/ijgi3031154>.

Entekhabi, D. et al. 2014. SMAP Handbook–Soil Moisture Active Passive: Mapping Soil Moisture and Freeze/Thaw from Space. Pasadena, CA USA: SMAP Project, JPL CL#14-2285, Jet Propulsion Laboratory.

Derksen, C., X. Xu,, R. S. Dunbar, A. Colliander, Y. Kim, J. Kimball. 2016. Soil Moisture Active Passive (SMAP) Project Calibration and Validation for the L3_FT_P and L3_FT_P_E Data Products (Version 1). SMAP Project, JPL D-56296. Jet Propulsion Laboratory, Pasadena, CA. (PDF, 2.6 MB)

Dunbar, S., X. Xu, A. Colliander, C. Derksen, K. McDonald, E. Podest. E. Njoku, J. Kimball, and Y. Kim. 2016. Algorithm Theoretical Basis Document (ATBD): SMAP Level 3 Radiometer Freeze/Thaw Data Products (L3_FT_P and L3_FT_P_E). SMAP Project, Jet Propulsion Laboratory, Pasadena, CA. (PDF, 8 MB)

Dunbar, S. 2016. SMAP Level 3 Freeze-Thaw (L3_FT_P) Product Specification Document. SMAP Project, JPL D-56293. Jet Propulsion Laboratory, Pasadena, CA. (PDF, 635 KB)

Frolking S., K. McDonald, J. Kimball, R. Zimmermann, J. B. Way and S. W. Running. 1999. Using the space-borne NASA Scatterometer (NSCAT) to determine the frozen and thawed seasons of a boreal landscape. *Journal of Geophysical Research*, 104(D22), 27,895-27,907.

Kim, Y., J. S. Kimball, K. Zhang, and K. C. McDonald. 2012. Satellite detection of increasing northern hemisphere non-frozen seasons from 1979 to 2008: implications for regional vegetation growth. *Remote Sensing of Environment*, 121, 472-487.

Kim, Y., J. S. Kimball, J. Glassy, and K. C. McDonald. 2014. MEaSURES Global Record of Daily Landscape Freeze/Thaw Status. Version 3. [indicate subset used]. Boulder, Colorado USA: NASA National Snow and Ice Data Center Distributed Active Archive Center.

<http://dx.doi.org/10.5067/MEASURES/CRYOSPHERE/nsidc-0477.003>.

Kim, Y., J.S. Kimball, K.C. McDonald and J. Glassy, 2011. Developing a global data record of daily landscape freeze/thaw status using satellite passive microwave remote sensing. *IEEE Transactions on Geoscience and Remote Sensing* 49, 949-960.

Kimball, J., K. McDonald, A. Keyser, S. Frolking, and S. Running. 2001. Application of the NASA Scatterometer (NSCAT) for Classifying the Daily Frozen and Non-Frozen Landscape of Alaska, *Remote Sensing of Environment*, 75, 113-126.

Kimball, J.S., K.C. McDonald, S.W. Running, and S. Frolking. 2004a. Satellite radar remote sensing of seasonal growing seasons for boreal and subalpine evergreen forests. *Remote Sensing of Environment*, 90, 243-258.

Kimball, J.S., M. Zhao, K.C. McDonald, F.A. Heinsch, and S. Running. 2004b. Satellite observations of annual variability in terrestrial carbon cycles and seasonal growing seasons at high northern latitudes. In *Microwave Remote Sensing of the Atmosphere and Environment IV*, G. Skofronick Jackson and S. Uratsuka (Eds.), *Proceedings of SPIE - The International Society for Optical Engineering*, 5654, 244-254.

McDonald, K.C., J.S. Kimball, E. Njoku, R. Zimmermann, and M. Zhao. 2004. Variability in springtime thaw in the terrestrial high latitudes: Monitoring a major control on the biospheric assimilation of atmospheric CO₂ with spaceborne microwave remote sensing. *Earth Interactions*, 8(20), 1-23.

Podest, E., K.C. McDonald, and J.S. Kimball. 2014. Multi-sensor microwave sensitivity to freeze-thaw dynamics across a complex boreal landscape. *Transactions in Geoscience and Remote Sensing*, 52, 6818-6828.

Rawlins, M. A, K. C. McDonald, S. Frolking, R. B. Lammers, M. Fahnestock, J. S. Kimball, C. J. Vorosmarty. 2005. Remote Sensing of Pan-Arctic Snowpack Thaw Using the SeaWinds Scatterometer, *Journal of Hydrology*, 312/1-4, 294-311.

Rignot E., and Way, J.B. 1994. Monitoring freeze-thaw cycles along north-south Alaskan transects using ERS-1 SAR, *Remote Sensing of Environment*, 49, 131-137.

Rignot, E., Way, J.B., McDonald, K., Viereck, L., Williams, C., Adams, P., Payne, C., Wood, W., and Shi, J. 1994. Monitoring of environmental conditions in taiga forests using ERS-1 SAR, *Remote Sensing of Environment*, 49, 145-154.

Way, J. B., R. Zimmermann, E. Rignot, K. McDonald, and R. Oren. 1997. Winter and Spring Thaw as Observed with Imaging Radar at BOREAS, *Journal of Geophysical Research*, 102(D24), 29673-29684.

Wismann, V. 2000. Monitoring of seasonal thawing in Siberia with ERS scatterometer data. *IEEE Transactions on Geoscience and Remote Sensing*, 38, 1804–1809.

5 DOCUMENT INFORMATION

5.1 Publication Date

3 January 2019

5.2 Date Last Updated

27 August 2020